

<b>Datum</b> 21.04.2021	<b>Seite</b> 1 von 3	<b>Formblatt</b>	
<b>FB -Nr.:</b> 122	<b>Revision</b> E		

<b>Ihre Auftrags- / Anfrage Nr. / Your Order/Inquiry No.</b>	<b>Unsere Bearbeitungs- Nr. / Our File No.</b>	<b>Datum / Date</b>

<b>1. Filtrationsart / Kind of filtration</b>			
<input type="checkbox"/>	Produktfiltration / <i>Product filtration</i>	<input type="checkbox"/>	Klärfiltration / <i>Clarification filtration</i>

<b>2. Filterpresse / filter press</b>									
<b>2.1</b>	Hersteller / Typ <i>Manufacturer / Type</i>								
<b>2.2</b>	Plattenformat <i>Format of plate</i>		[mm]	Nutzlänge <i>Usable length</i>		[mm]			
<b>2.3</b>	<input type="checkbox"/>	Neuausrüstung / <i>New equipment</i>	<input type="checkbox"/>	Nachrüstung / <i>Supplementary</i>		<input type="checkbox"/>	Umrüstung / <i>Refurbishment</i>		
<b>2.4</b>	<input type="checkbox"/>	Kammerplattensystem <i>Chamber plate system</i>	<input type="checkbox"/>	Membranplattensystem <i>Membrane plate system</i>		<input type="checkbox"/>	Platten-Rahmen-System <i>Plate-frame-system</i>		
<b>2.5</b>	Anzahl der / <i>Number of</i>								
	Platten <i>Plates</i>		Stück <i>pcs.</i>	Membranplatten <i>Membrane plates</i>		Stück <i>pcs.</i>	Rahmen <i>Frames</i>		Stück <i>pcs.</i>
<b>2.6</b>	Plattentransport / <i>Plate shifting</i>		<input type="checkbox"/>	manuell / <i>manual</i>		<input type="checkbox"/>	automatisch / <i>automatic</i>		
<b>2.7</b>	Schließvorrichtung / <i>Closing device</i>		<input type="checkbox"/>	hydraulisch / <i>hydraulic</i>		<input type="checkbox"/>	mechanisch starr / <i>mechanically rigid</i>		
<b>2.8</b>	Plattenmaterial <i>Plate material</i>		Membranmaterial <i>Membrane material</i>			Dichtungsmaterial <i>Sealing material</i>			

<b>3. Angaben zur Chemie im Prozess / Specification on chemicals in contact</b>						
<b>3.1</b>	<b>Suspension / Slurry</b>					
	Bezeichnung (chem. Formel) <i>Name (chemical formula)</i>	Konzentration <i>Concentration</i>	Feststoffgehalt <i>Solid content</i>	Dichte <i>Density</i>	Korngröße <i>Particle size</i>	pH Wert <i>pH Value</i>
		[%]	[%]	[g/cm <sup>3</sup> ]	[µm]	[1]
Suspension <i>Slurry</i>		X			X	
Feststoff <i>Solid</i>	Zusammensetzung <i>Composition</i>		X			X
1			X			X
2			X			X
3			X			X
4			X			X
5			X			X
Flüssigkeit <i>Liquid</i>	Zusammensetzung <i>Composition</i>		X			X
1			X			X
2			X			X
3			X			X
4			X			X
5			X			X
<b>3.2</b>	<b>Rückmeldung Ergebnis / Feedback Result</b>					
Kuchen <i>Cake</i>		X			X	
Filtrat <i>Filtrate</i>		X			X	

<b>JVK Filtration Systems GmbH</b>	Telefon 09172 707 0	E-Mail <a href="mailto:JVK@JVK.de">JVK@JVK.de</a>
	Telefax 09172 707 77	Internet <a href="http://www.jvk.de">www.jvk.de</a>

<b>Datum</b> 21.04.2021	<b>Seite</b> 2 von 3	<b>Formblatt</b>	 <b>JVK®</b>
<b>FB -Nr.:</b> 122	<b>Revision</b> E		

4. Betriebsbedingungen / Operating Conditions							
		Filtration	Kuchen Waschen <i>Cake washing</i>	Nachpressen <i>Squeezing</i>	Kuchen blasen <i>Cake blowing</i>	Kuchentrocknung <i>Cake drying</i>	
Medium / <i>Media</i>		X					
Max. Temperatur <i>Max. Temperature</i>	[°C]					TCC	TCM
Max. Druck <i>Max. Pressure</i>	[MPa]					TCC	TCM
Zeit / <i>Time</i>	[min]						

5. Filtertuch / Filter cloth					
<input type="checkbox"/>	Durchstecktuch / <i>Barrelneck cloth</i>	<input type="checkbox"/>	Überhangtuch / <i>Drape over cloth</i>	<input type="checkbox"/>	Stütztuch / <i>Support cloth</i>
Materialtyp / <i>Typ of material</i>	Webfaden / <i>Weave thread</i>		Dicke / <i>Thickness</i> [mm]	Luftdurchlässigkeit / <i>Permeability</i> [l/dm <sup>2</sup> /min]	
	monofilament	multifilament			
	<input type="checkbox"/>	<input type="checkbox"/>			

6. Filterplattensatz / Set of filter plates						Nur für Nach- oder Umrüstung <i>For supplement or convert only</i>	
je bestehend aus / each consisting of:							
Plattentyp <i>Type of plate</i>	Anzahl / quantity		Ausführung als / <i>Design for</i>		Dicke <i>Thickness</i>	Zeichnung-Nr. (wenn bekannt) <i>Drawing no.</i> (if known)	
	Im Paket <i>In the pack</i>	Ersatz <i>Spare</i>	Waschen_Blasen / <i>Washing_Blowing</i>				
Kopfplatte <i>Head plate</i>			Druckplatte <i>Press plate</i>	Waschplatte <i>Wash plate</i>		[mm]	
Endplatte <i>End plate</i>						[mm]	
Membranplatte <i>Membrane plate</i>						[mm]	
Kombinationsplatte <i>Combination plate</i>						[mm]	
Filterplatte <i>Filter Plate</i>						[mm]	
Rahmen <i>Frame</i>						[mm]	
Kammertiefe (Kuchendicke vor Nachpressen) <i>Chamber depth (Cake thickness bevor squeezing)</i>						[mm]	
Position der Trübebohrung / <i>Position of feed hole</i>							
Mitte <i>Centre</i>	<input type="checkbox"/>	Mitte Oben <i>Top centre</i>	<input type="checkbox"/>	Mitte unten <i>Bottom centre</i>	<input type="checkbox"/>	Ecke <i>Corner</i>	<input type="checkbox"/>
Oben links <i>Top left</i>	<input type="checkbox"/>	Oben rechts <i>Top right</i>	<input type="checkbox"/>	Unten links <i>Bottom left</i>	<input type="checkbox"/>	Unten rechts <i>Bottom right</i>	<input type="checkbox"/>
Durchmesser der Trübebohrung <i>Diameter of feed hole</i>			[mm]	Stütz- und Verteilerring <i>Support and distribution ring</i>		Ja / yes	<input type="checkbox"/>
						Nein / no	<input type="checkbox"/>
Position der Filtratablaufbohrung / <i>Position of flow hole</i>							
Oben links <i>Top left</i>	<input type="checkbox"/>	Oben rechts <i>Top right</i>	<input type="checkbox"/>	Unten links <i>Bottom left</i>	<input type="checkbox"/>	Unten rechts <i>Bottom right</i>	<input type="checkbox"/>
Kopfplatte <i>Head plate</i>	mit Linersystem <i>with liner system</i>	Ja / yes <input type="checkbox"/>	Nein / no <input type="checkbox"/>	Endplatte <i>End plate</i>	Trübekanal freiblasen vorsehen <i>Considered for core blow</i>	Ja / yes <input type="checkbox"/>	Nein / no <input type="checkbox"/>
Größe des Nachpressanschlusses <i>Size of connection for squeezing pressure</i>			M	Inch	G	R	R <sub>P</sub>
							NPT
							Stahlqualität / <i>steel quality</i>

<b>JVK Filtration Systems GmbH</b>	Telefon 09172 707 0	E-Mail <a href="mailto:JVK@JVK.de">JVK@JVK.de</a>
	Telefax 09172 707 77	Internet <a href="http://www.jvk.de">www.jvk.de</a>

<b>7. Griffsituation / handle situation</b>			
<b>7.1</b>	Griffzeichnungsnummer / handle drawing number	(wenn bekannt / if known)	
<b>7.2</b>	Seitenholmform / form of side bars	rund / round <input type="checkbox"/>	rechteckig / rectangular <input type="checkbox"/>

Bitte tragen Sie die aktuellen Maße in die Tabellen neben den nachfolgenden Skizzen ein.  
Please fill in the actually measurement in to the table next to the following draft.

Maßskizze / Draft

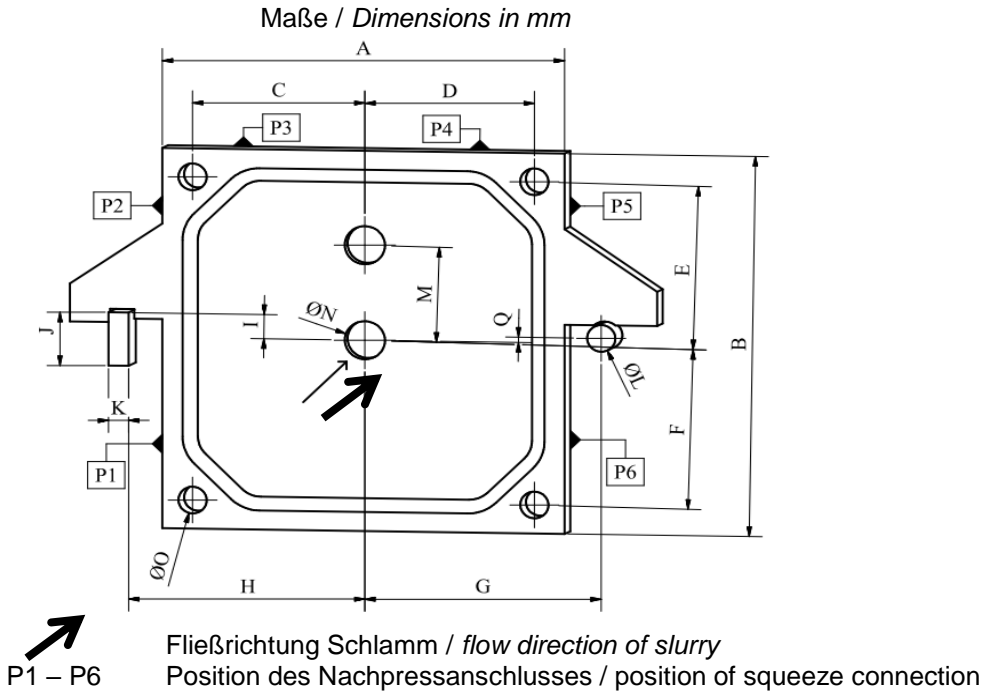

A
B
C
D
E
F
G
H
I
J
K
L
M
N
O
P
Q

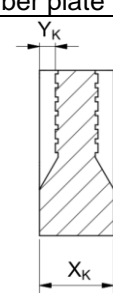
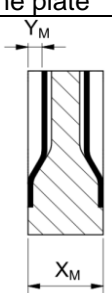
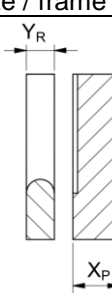
Kammerplatte Chamber plate	Membranplatte Membrane plate	Filterplatte / Rahmen Filter plate / frame		
			X_K	
			Y_K	
			X_M	
			Y_M	
			X_P	
			Y_R	

**Falls der vorgesehene Platz im Formular nicht ausreicht, erweitern Sie diesen bitte durch Beilagen.**  
**If there is not enough space in the form to fill in, please feel free to add enclosure to it.**

Die Richtigkeit der Angaben wird bestätigt:  
The accuracy of the information is confirmed:

-----  
Datum / date      Unterschrift Kunde / signed by customer

Dieser Fragebogen ist Teil der technischen Klärung und somit Bestandteil des Vertrages. Schäden an unseren Produkten, die aufgrund fehlender oder falscher Angaben zur Auslegung dieser, entstehen, können der JVK Filtration Systems GmbH zu keinem Zeitpunkt zur Last gelegt werden.  
This questionnaire is part of the technical clarification and therefore part of the contract. JVK Filtration Systems GmbH can at no time be held responsible for damage to our products caused by missing or incorrect information on the design of these.